

NANOMEFOS

Nanometer Accuracy Non-contact Measurement of Free-form Optical Surfaces

Rens Henselmans¹, Nick Rosielle¹, Pieter Kappelhof²

¹Eindhoven University of Technology, faculty of Mechanical Engineering, Constructions & Mechanisms group, P.O. Box 513, 5600 MB Eindhoven, The Netherlands

²TNO TPD, Optical Instrumentation Division, Precision Mechanics section,
P.O. Box 155, 2600 AD Delft, The Netherlands

E-mail address corresponding author: r.henselmans@tue.nl

Abstract

This paper describes a conceptual measurement machine design, aiming for universal and non-contact form measurement of free-form optical surfaces up to \varnothing 500 mm with an uncertainty of 30 nm ($k = 2$). This conceptual design is the result of a M.Sc. graduation assignment done within Eindhoven University of Technology (TU/e) in collaboration with TNO TPD. Recently a PhD study has started at TU/e called NANOMEFOS (Nanometer Accuracy Non-contact Measurement of Free-form Optical Surfaces), to further develop this concept. In this paper, first the requirements and current metrology methods with respect to these requirements will be discussed. Next, the machine concept and the calculation of the error budget will be explained. Finally, a short overview of the current design will be given.

Introduction

At the Optical Instrumentation Division of TNO TPD, complex optical systems are being designed and built for science, space and lithography applications. By applying advanced aspherical and free-form optics, the optical quality of these systems can be increased and system size, cost and weight can be reduced. For a few years TNO TPD has therefore been developing and testing new shaping technologies for manufacturing these large complex surfaces. At the moment the first aspherical and free-form optical surfaces are being manufactured on the diamond turning machine with slow-tool-servo (Precitech Nanoform 350) and the Fluid Jet Polishing robot [1] (fig. 1).

Also under development is metrology for in-process monitoring of material removal and surface quality in these manufacturing processes [1]. These techniques allow fast and accurate shaping of the surface because the required number of iterative steps can be reduced. What is missing in this product manufacturing cycle is a method of determining absolute surface form before corrective polishing and to check the surface when finished.

In a collaboration of the TU/e Constructions & Mechanisms group and TNO TPD, a new non-contact measurement machine concept has therefore been developed in a M.Sc. graduation assignment [2]. In succession, a new project called NANOMEFOS (Nanometer Accuracy Non-contact Measurement of Free-form Optical Surfaces) has recently started for further development of this concept. This paper describes the conceptual design of this new non-contact measurement machine for free-form optical surfaces.



Figure 1: Free-form optics production facilities at TNO TPD

Requirements

Based on the future demands of TNO TPD optical designers and manufacturing capabilities, the requirements for the metrology system are as described below:

The TNO TPD polishing robot and diamond turning machine are both able to load work pieces up to about \varnothing 500 mm x 100 mm, therefore the metrology system should be able to measure products up to these dimensions. Further, a maximal mass of 50 kg is assumed. Desired form accuracy for high-end optics is up to $\lambda/20$, which is equal to about 30 nm uncertainty ($k=2$) for visible light. To prevent polished and coated surfaces from being damaged, the system should measure non-contact.

High-end optics production usually is a typical single-piece production environment. Therefore the metrology system should be able to universally measure most types of optical surfaces. These surface types can be divided into flat, spherical, aspherical, free-form and off-axis. For aspherical surfaces an 'unlimited' departure from the best-fit-sphere is allowed and for free-form surfaces a maximal departure from rotational symmetry of 5 mm is assumed. Further, convex as well as concave surfaces should be measured with slopes up to 45° . Finally, transmission as well as reflection optics should be measured, where a minimal reflectivity of 5% is assumed.

The optical surfaces will be pre-polished before they are measured, so surface shape is smooth and roughness is in the order of a few nm. Because the metrology system has to measure only form, a lateral resolution of about 1 mm is sufficient. For double-sided optics (transmission optics), usually one side is completely finished first before the other side is manufactured. Therefore only one side needs to be measured.

A maximal measurement time of about 10 minutes for the largest surfaces is assumed. This measurement time does not include the acclimatization of the product. The machine will be placed in a conditioned environment where the temperature is estimated to be $20 \pm 0,2$ °C.

Current metrology methods

For universally measuring complex (aspherical and free-form) optical surfaces, Co-ordinate Measuring Machines (CMMs) can be used. To increase accuracy, CMMs have been equipped with laser interferometers and large reference mirrors [3]. To convert CMMs to non-contact measurement, an optical probe could be used. Because of the large surface slopes, this probe should be positioned perpendicular to the surface. Most CMMs have an orthogonal machine setup, which makes it difficult to implement this with maintained accuracy.

For positioning a probe perpendicular to a (spherical) surface, polar CMMs have been developed [4]. Presently these machines use a measuring contact probe because of the lack of a suitable optical probe. For measuring different surface sizes and radii, the machine setup of these machines has to be changed completely. Because calibration is very difficult, the machine uncertainty completely depends on the used set of calibration lenses.

For measuring aspheres, contour profilers are mostly used [5]. By adding a lateral stage, this 2D method can be converted to 3D. It however remains a contact method and is difficult to scale to the required measurement volume.

Surface slope [6], slope difference [7] or curvature [8] can be measured by scanning a (non-contact) optical probe over the surface. By respectively single and dual integration, surface form can be obtained. These methods are mainly suitable for measuring deviation from flat or spherical. When surfaces become more complex, the vulnerability to integration errors increases. For accurate measurement of form, measuring co-ordinates is therefore preferred.

For measuring flat and spherical optics, Phase Shifting Interferometers (PSI) are mostly used. To adapt the wavefront to the complex surfaces to be measured, specially calibrated null lenses or Computer Generated Holograms (CGH) can be used [9]. These methods are not universal, and the

measurement uncertainty completely depends on the calibrated null lenses and CGHs. This method therefore is not suitable for use in a single piece production environment.

Another way to adapt a PSI wavefront to a complex surface is by decreasing the aperture and stitching the sub-apertures together based on surface information [9]. However, because of the little surface information present in optical surfaces, this method is very vulnerable to stitching errors. The form difference of the (many) sub-apertures is small for typical optical surfaces, and there is also very little roughness. For measuring the complete range of radii as mentioned in the requirements, the PSI also has to be adapted (convex and concave) and repositioned, which is another potentially large source of uncertainty.

Conceptual design

None of the above current metrology methods can presently meet the described combination of requirements. A new concept has therefore been developed. The above review of current metrology methods has shown that the best way to universally measure all types of surfaces is a scanning method. To avoid integration errors, measuring co-ordinates is preferred to slope or curvature. Because the optical surfaces described in the requirements are more or less rotationally symmetric (or part of a rotationally symmetric surface), a cylindrical machine setup was chosen (fig. 2). The surface to be measured is mounted on an air-bearing spindle (θ) and a non-contact optical distance sensor is moved radially over the surface by the R,Z-mechanism. Because of the large surface slopes, this sensor should be positioned approximately perpendicular to the surface and is therefore mounted on an axis ϕ .

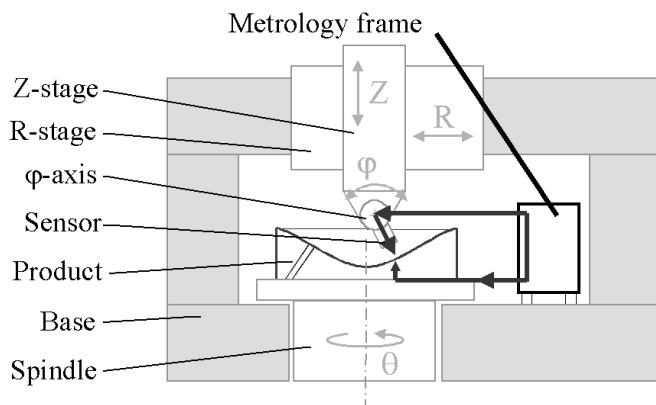

Figure 2: The schematic cylindrical machine setup with metrology frame and metrology loop

The sensor uncertainty and the uncertainty of the sensor position with respect to the surface determine the eventual measurement uncertainty. To create a short and closed metrology loop, a metrology frame is applied, which serves as a reference relative to which the sensor position and the product position will be measured as directly as possible.

To be able to measure free-form surfaces swiftly (with a continuous rotation of the spindle), the non-rotationally symmetric deviations should be captured in the sensors range, which should therefore be 5 mm. The R,Z, ϕ -mechanism can then be stationary while measuring a 'track', which reduces system dynamics and thus increases repeatability.

When measuring free-forms, the surface will not be perpendicular to the sensor in the direction tangent to the circumference. Because free-form deviations are assumed to be small and smooth, this can probably be captured within the sensors' angular range. Further investigation will show to what level this effect can be accepted.

Error budget calculation

For the concept of figure 2, the error budget has been calculated to derive the requirements for the subsystems. In these calculations the main focus is on repeatability because calibration and software correction will compensate for the systematic errors. The sensor is assumed to be rigidly connected to the φ -axis, and the metrology frame is also assumed to be rigid. This means that there are 13 position measurement errors that might cause an eventual measurement error:

- The distance measurement error of the sensor (ϵ_{sensor}).
- 6 degrees of freedom of the φ -axis with respect to the metrology frame (ϵ_{axis}).
- 6 degrees of freedom of the spindle with respect to the metrology frame ($\epsilon_{\text{spindle}}$).

Because measurement is being performed to smoothly curved pre-polished surfaces (roughness in the order of a few nanometers), not every error has the same influence on the eventual measurement error. This effect is illustrated in figure 3. A position measurement error ϵ perpendicular to the surface results in a direct measurement error δ , but a position measurement error tangent to the surface results in a 2nd order error. The minimal radius of curvature of the surfaces was assumed to be 15 mm, so a tangent error of about 20 μm results in only 15 nm of measurement error.

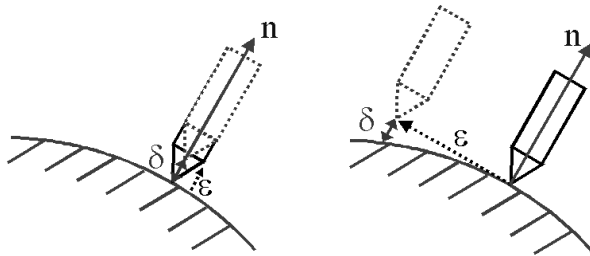

Figure 3: The 2nd order effect

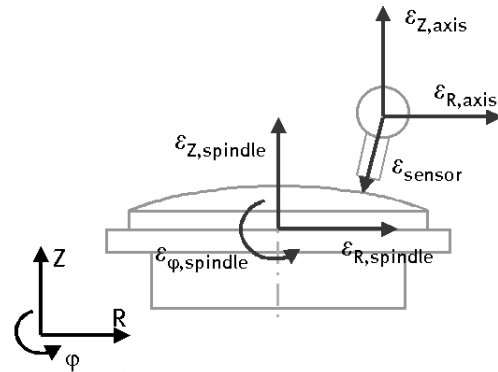

Figure 4: The critical error sources

For spherical optics, this effect has been calculated for all radii of curvature to be measured and all measurement positions. It appears that there's a clear distinction between critical and less-critical positioning errors. Nanometer uncertainty is only required for 6 of the 13 potential error sources. For the remaining sources, micrometer uncertainty is required. All 6 critical error sources are within the plane of motion of the sensor (as shown in figure 4), the real metrology problem thus becomes a 2D issue. This effect is also present with aspherical and free-form optics, but further calculations have to show to what extent exactly.

Current design

The measuring machine design will not be discussed in detail because it is still under development. An overview picture of the current design is shown in figure 5. Main features of the design are:

- A light and stiff machine construction to position the sensor with respect to the product. With a parallel air-bearing slide construction the sensor is aligned to a vertical reference surface to provide an accurate plane of motion and good dynamical behavior.
- To measure the sensor position with respect to the product, an interferometry system directly measures

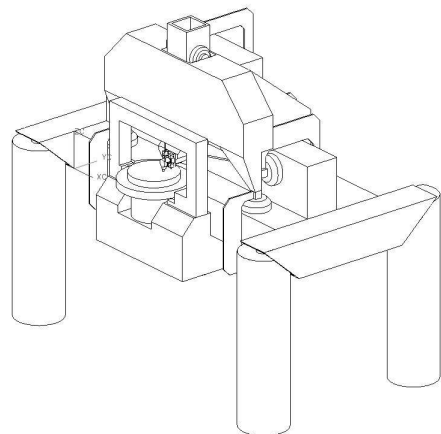

Figure 5: The current machine concept

the position of the translating and rotating sensor with respect to the metrology frame. The product position is also measured, resulting in a short and closed metrology loop and canceling out many slide motion errors.

- A non-contact sensor concept with 5 mm range and nanometer uncertainty to capture free-form deviations within the sensors range. This way these large complex surfaces can be measured fast (in a few minutes) and with relatively little system dynamics.

Conclusion

The preliminary study described in this paper has shown that the requirements are feasible, especially on the part of non-contact universal measurement of large surfaces. Further investigation will show what final measurement uncertainty may be achieved. Development of this concept will take place in a PhD study at Eindhoven University of Technology, in collaboration with TNO TPD. The main focus will be on a more detailed error budget calculation for measuring free-form surfaces and further study on the interferometry system and the non-contact sensor concept. Finally also minimizing the influence of environmental disturbances (vibrations and refractive index variations) will be researched. The design is expected to be finished late 2004 and from then on a prototype will be built, tested and calibrated which is expected to be completed early 2007.

References

- [1] Brug, H. van, Dorrepaal, M., Saunders, I., "*Polishing robot based on FJP with in-situ monitoring system*", Proc. of SPIE, Vol. 5180, 2004, pp. 101 – 106
- [2] Henselmans, R., "*Design of a Non-contact Measurement Machine for Free-form Optical Surfaces*", Masters' Thesis, in Dutch, Eindhoven University, 2003
- [3] Becker, K. and Heynacher, E., "*M400 - A Co-ordinate Measuring Machine with 10 nm Resolution*", SPIE, Vol. 802, 1987, pp. 209 - 216
- [4] Loh TII-3D, <http://www.loh.de>, 2003
- [5] Form Talysurf PGI 1240, <http://www.taylor-hobson.com>, 2003
- [6] Beek, N.A.J. van der, Amstel, W.D. van, et. al., "*Deflectometry on aspheric surfaces: A new approach and generic solution for measuring 'free form' aspheres*", Proc. of the 3rd Euspen International Conference, Eindhoven, 2002, pp. 657 – 660
- [7] Geckeler, R.D., Weingärtner, I., "*Sub-nm Topography Measurement by Deflectometry: Flatness Standard and Wafer Nanotopography*", Proc. of the 2nd Euspen International Conference, Eindhoven, 2002, pp. 497 – 500
- [8] Thomson-Schmidt, P., Schulz, M., Weingärtner, I., "*A facility for the curvature-based measurement of the nanotopography of complex surfaces*", Proc. of SPIE, Vol. 4098, 2000, pp. 94 – 101
- [9] Malacara, D., et.al., "*Optical Shop Testing*", Second Edition, Wiley-Interscience, ISBN 0-471-52232-5, 1992